

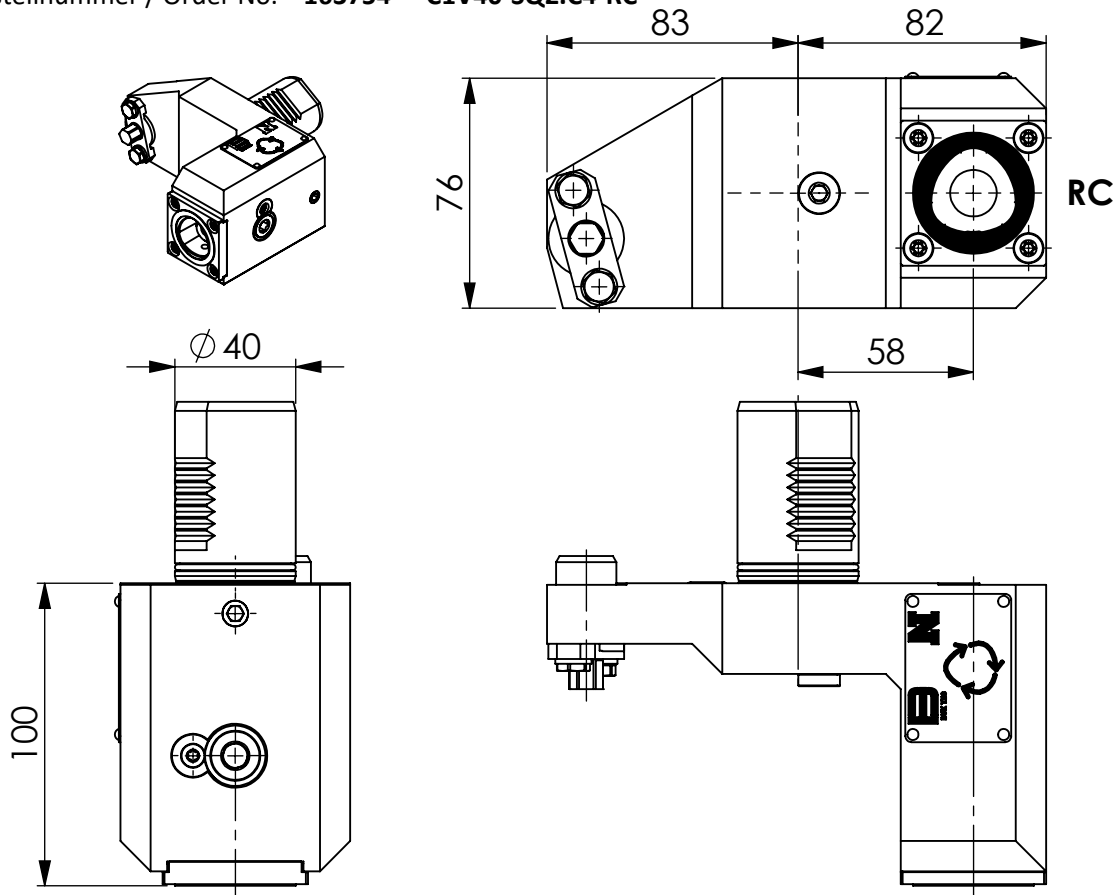

SPANNEINHEIT PSC40, GERADE

CLAMPING UNIT PSC40, AXIAL

Bestellnummer / Order No. 163754 - C1V40-SQ2.C4-RC



Technische Daten

Technical specifications

Schaft Shank	Spannbereich clamping range	Kühlungsart Coolant Type	Druck Pressure	Richtung Direction	Gewicht weight
Ø mm	Ø mm	Emulsion	p max bar		kg
40 VDI	Polygon - DIN ISO 26623-2 - PSC40 - RC	ext./int.	80	ger./str.	4.64

Erforderliches Zubehör nicht im Lieferumfang enthalten
necessary equipment not included

Spannzangensatz collet set test	Spann Schlüssel Clamping wrench	Haken Schlüssel Hook wrench
-	-	-